

DEVELON

Mini Excavator

DX35Z-7



Engine

| | |
|---------------------------------------|-------------------------------------|
| Make | DEVELON |
| Model | DN1.7 |
| Number of cylinders | 3 |
| Rated power, gross (hp per SAE J1995) | 24.7 hp (18.4 kW) @ 2200 rpm |
| Rated power, net (hp per SAE J1349) | 24.1 hp (18.0 kW) @ 2200 rpm |
| Max. torque, net (SAE J1995) | 72 lbf.ft. (9.9 kgf.m) @ 1600 rpm |
| Displacement | 101 in. ³ (1.65 L) |
| Bore and stroke | 3.4 in. x 3.6 in. (87 mm x 92.4 mm) |
| Starter | 12 V, 2.3 hp (1.7 kW) |
| Battery | 12 V, 55 AH |
| Alternator | 13.5 V, 75 amp |
| Air cleaner | Double elements |

Hydraulics

| | |
|--------------------------|------------------------------------|
| Main pumps | 2 x 10 gpm (37 L/min.) |
| Pilot pump (gear design) | 3 gpm (11 L/min.) |
| Relief pressure | 3983 psi (280 kg/cm ²) |

Maximum System Pressure

| | |
|-------------------------------|------------------------------------|
| Boom/arm/bucket (normal mode) | 3553 psi (250 kg/cm ²) |
| Swing (crossover relief) | 3129 psi (220 kg/cm ²) |

Undercarriage

| | |
|----------------------------------|--------------------------|
| Upper rollers (each track) | 1 |
| Lower rollers (each track) | 4 |
| Number of shoes (links per side) | Single assembly (rubber) |

Swing Mechanism

| | |
|--------------|--------------------------|
| Swing speed | 8.3 rpm |
| Swing torque | 6280 lbf.ft. (868 kgf.m) |

Drive System

| | |
|-------------------------------------|----------------------------------|
| Travel speed (low – high) | 1.55 – 2.67 mph (2.5 – 4.3 km/h) |
| Traction force, max. (drawbar pull) | 9851 lbf. (4468 kgf) |
| Max. grade | 58% (30°) |

Environment

| | |
|------------------------------|----------|
| Sound level (ISO 6395) | 94 dB(A) |
| Cabin sound level (ISO 6396) | 78 dB(A) |

Refill Capacities

| | |
|------------------------------------|-------------------|
| Fuel tank | 12.42 gal. (47 L) |
| Cooling system (radiator capacity) | 1.27 gal. (4.8 L) |
| Engine oil | 1.53 gal. (5.8 L) |
| Final drive (each side) | 0.2 gal. (0.9 L) |
| Hydraulic system | 12.9 gal. (49 L) |
| Hydraulic tank | 12.94 gal. (49 L) |

Hydraulic Cylinders

| | |
|--|--|
| Boom ¹ (1) bore x rod diameter x stroke | 3.1 in. x 24.9 in. x 2 in. (80 mm x 633 mm x 50 mm) |
| Arm ^{1,2} (1) bore x rod diameter x stroke | 3.1 in. x 28.6 in. x 2.2 in. (80 mm x 726 mm x 55 mm) |
| Bucket ¹ (1) bore x rod diameter x stroke | 2.8 in. x 23.6 in. x 1.8 in. (70 mm x 600 mm x 45 mm) |
| Swing – boom ¹ (1) bore x rod diameter x stroke | 3.5 in. x 17.7 in. x 2.4 in. (90 mm x 449 mm x 60 mm) |
| Blade ¹ (2) bore x rod diameter x stroke | 4.3 in. x 7.8 in. x 2.4 in. (110 mm x 197 mm x 60 mm) |

¹ Cushion on rod end

² Cushion on base end

The piston rods and cylinder bodies are made of high-strength steel. A shock-absorbing mechanism is fitted in all cylinders to ensure shock-free operation and extended piston life.

Dimensions

| | | Standard Arm & HVAC Cabin (U520) | Long Arm & HVAC Cabin (U521) | Standard Arm & Canopy (U530) | Long Arm & Canopy (U531) |
|------------------------------|---|---|---------------------------------|---------------------------------|-----------------------------|
| Boom type | | 8' 3" (2535 mm) | | | |
| Arm type | | 4' 4" (1330 mm) | 4' 11" (1500 mm) | 4' 4" (1330 mm) | 4' 11" (1500 mm) |
| Bucket type (SAE) | | 3.9 ft. ³ (0.11 m ³) | | | |
| Track type | | Fixed (rubber) | | | |
| Shipping length | A | 15' 8" (4777 mm) | 15' 7" (4760 mm) | 15' 8" (4777 mm) | 15' 7" (4760 mm) |
| Overall height | B | 8' 1" (2479 mm) | | | |
| Shipping width | C | 5' 6" (1700 mm) | | | |
| Tail swing radius | D | 2' 10" (872 mm) | 3' 1" (945 mm) | 2' 10" (872 mm) | 3' 1" (945 mm) |
| Tail swing overhang (rear)* | | - | | | |
| Tail swing overhang (side) | E | 0.9" (22 mm) | 3.7" (95 mm) | 0.9" (22 mm) | 3.7" (95 mm) |
| Counterweight clearance | F | 1' 9" (537 mm) | | | |
| Upper structure width | H | 4' 11" (1500 mm) | | | |
| Cabin height above house | I | 3' 2" (971 mm) | 3' 6" (1067 mm) | 3' 2" (971 mm) | 3' 6" (1067 mm) |
| Tumbler distance | J | 5' 7" (1700 mm) | | | |
| Overall track length | K | 6' 11" (2121 mm) | | | |
| Undercarriage width | L | 5' 7" (1700 mm) | | | |
| Track gauge | M | 4' 7" (1400 mm) | | | |
| Track width | N | 11.8" (300 mm) | | | |
| Track height | O | 1' 7" (475.5 mm) | | | |
| Car body clearance | P | 1' 6" (475.5 mm) | | | |
| Blade height | Q | 1' 3" (380 mm) | | | |
| Blade clearance | R | 1' 4" (410 mm) | | | |
| Max. blade cut, below ground | S | 1' 5" (429 mm) | | | |

*Not shown on diagram
Less than zero indicated as "-"

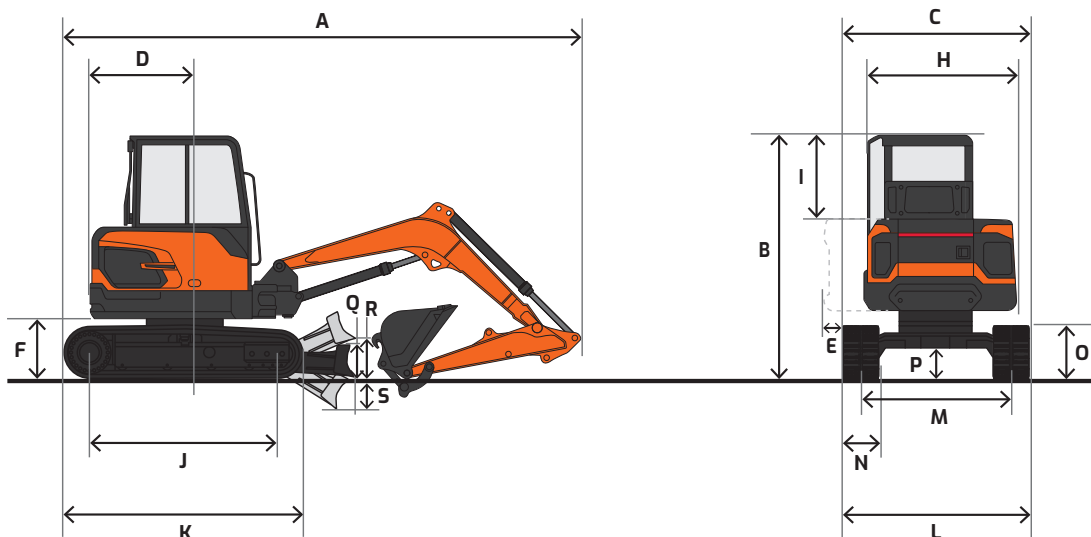

Working Range

| | | Standard Arm & HVAC Cabin (U520) | Long Arm & HVAC Cabin (U521) | Standard Arm & Canopy (U530) | Long Arm & Canopy (U531) |
|------------------------------|---|---|---------------------------------|---------------------------------|-----------------------------|
| Boom length | | 8' 4" (2535 mm) | | | |
| Arm length | | 4' 4" (1330 mm) | 4' 11" (1500 mm) | 4' 4" (1330 mm) | 4' 11" (1500 mm) |
| Bucket capacity (SAE) | | 3.9 ft. ³ (0.11 m ³) | | | |
| Max. digging reach | A | 17' 7" (5355 mm) | 18' 1" (5515 mm) | 17' 7" (5355 mm) | 18' 1" (5515 mm) |
| Max. digging reach (ground) | B | 17' 2" (5235 mm) | 17' 9" (5400 mm) | 17' 2" (5235 mm) | 17' 9" (5400 mm) |
| Max. digging depth | C | 10' 8" (3275 mm) | 11' 4" (3445 mm) | 10' 9" (3275 mm) | 11' 4" (3445 mm) |
| Max. dumping height | D | 11' 9" (3580 mm) | 12' 2" (3700 mm) | 11' 9" (3580 mm) | 12' 2" (3700 mm) |
| Max. digging height | E | 16' 8" (5095 mm) | 17' 1" (5215 mm) | 16' 9" (5095 mm) | 17' 1" (5215 mm) |
| Max. bucket pin height | F | 14' 3" (4345 mm) | 14' 8" (4460 mm) | 14' 3" (4345 mm) | 14' 8" (4460 mm) |
| Max. vertical wall depth | G | 6' 6" (1980 mm) | 6' 9" (2045 mm) | 6' 6" (1980 mm) | 6' 9" (2045 mm) |
| Max. vertical digging radius | H | 13' 10" (4215 mm) | 14' 3" (4350 mm) | 13' 10" (4215 mm) | 14' 3" (4350 mm) |
| Min. swing radius | I | 6' 11" (2115 mm) | 7' 0" (2145 mm) | 6' 11" (2115 mm) | 7' 0" (2145 mm) |
| Boom swing – left/right | | 66.5° / 53.5° | | | |
| Digging force, bucket (PCSA) | | 7143 lbf. (3240 kgf) | | | |
| Digging force, arm | | 4674 lbf. (2120 kgf) | 4299 lbf. (1950 kgf) | 4674 lbf. (2120 kgf) | 4299 lbf. (1950 kgf) |
| Counterweight | | 1389 lb. (630 kg) | | | |
| Operating weight | | 8558 lb. (3882 kg) | 8807 lb. (3995 kg) | 8320 lb. (3782 kg) | 8570 lb. (3895 kg) |
| Ground pressure | | 4.98 psi (0.35 kg/cm ²) | | | |

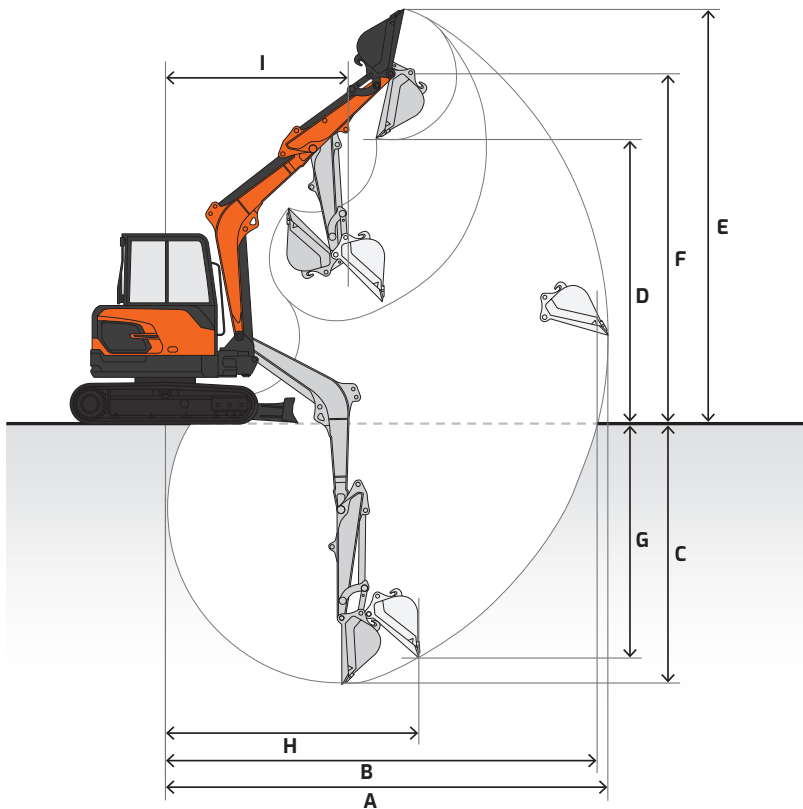

Bucket

| | Standard Arm & HVAC Cabin (US20) | Long Arm & HVAC Cabin (US21) | Standard Arm & Canopy (US30) | Long Arm & Canopy (US31) |
|-------------------|--|------------------------------------|------------------------------------|--------------------------------|
| Boom | 8' 2" (2500 mm) | | | |
| Arm | 4' 3" (1300 mm) | 4' 11" (1500 mm) | 4' 3" (1300 mm) | 4' 11" (1500 mm) |
| Shoe size | 11.8" (300 mm) | | | |
| Track type | Fixed (rubber) | | | |

| Bucket Type | Model | Capacity* yd ³ (m ³) | Width in. (mm) | Weight lb. (kg) | Height in. (mm) | Length in. (mm) | Number of teeth | Connection/ Type |
|---------------------------------------|-------------|--|-------------------|--------------------|--------------------|--------------------|--------------------|---------------------|
| Quick hitch Ditching (QH03GB) | DC03GB-30QH | 0.18 (0.14) | 30 (762) | 214 (97) | 17.625 (447.6) | 23.625 (600) | - | Quick hitch 1.25" |
| | DC03GB-36QH | 0.22 (0.17) | 36 (914.4) | 250 (113) | | | | |
| | DC03GB-42QH | 0.26 (0.19) | 42 (1,066.8) | 290 (131) | | | | |
| Quick hitch Heavy-Duty (QH03QB) | HD03GB-12QH | 0.06 (0.04) | 12 (304.8) | 125 (56) | 18.375 (466.7) | 30.875 (784.2) | 3 | Quick hitch 1.25" |
| | HD03GB-16QH | 0.09 (0.07) | 16 (406.4) | 155 (70) | | | 4 | |
| | HD03GB-18QH | 0.1 (0.07) | 18 (457.2) | 160 (72) | | | 4 | |
| | HD03GB-24QH | 0.14 (0.10) | 24 (609.6) | 200 (91) | | | 5 | |
| Pin-on Ditching | DC03GB-30 | 0.18 (0.14) | 31 (787.4) | 235 (106) | 23 (584.2) | 26.75 (679.4) | - | Pin-on |
| | DC03GB-36 | 0.23 (0.17) | 37 (939.8) | 270 (122) | | | | |
| | DC03GB-42 | 0.26 (0.2) | 43 (1,092.2) | 300 (136) | | | | |
| Pin-on Heavy-Duty | HD03GB-12 | 0.06 (0.04) | 13 (330.2) | 150 (68) | 22.625 (574.6) | 32 (812.8) | 3 | Pin-on |
| | HD03GB-16 | 0.09 (0.07) | 17 (431.8) | 175 (79) | | | 4 | |
| | HD03GB-18 | 0.1 (0.07) | 19 (482.6) | 200 (91) | | | 4 | |
| | HD03GB-20 | 0.11 (0.08) | 21 (533.4) | 205 (93) | | | 5 | |
| | HD03GB-24 | 0.14 (0.10) | 25 (635) | 220 (100) | | | 5 | |

*Capacity based on ISO 7451 and heaped with a 1:1 angle of repose

• Equipped with bolt-on wear shrouds

• Equipped with bolt-on teeth

• Equipped with bolt-on cutting edge

• These recommendations are given as a guide only and based on typical operating conditions.

Please consult with your DEVELON dealer to properly match buckets and attachments for the application.

Lifting Capacity

Rating over front Rating over side or 360°

DX35Z-7 US20/US21

Boom: 6' 10" (2090 mm) | Arm: 4' 4" (1330 mm) | Counterweight: 322 lb. (146 kg) | Bucket: None | Unit lb. (kg)

| A (ft. or m) B (ft. or m) | 3' 3" (1.0 m) | | | 6' 7" (2.0 m) | | | 9' 10" (3.0 m) | | | 13' 1" (4.0 m) | | | Max. Reach | | | |
|------------------------------------|--------------------|--------------------|--------------------|--------------------|--------------------|---------------|--------------------|-------------------|-------------------|--------------------|--------------|--------------|--------------------|--------------|--------------|-----------------|
| | | | | | | | | | | | | | | | | A |
| 13' 1" (4.0 m) | | | | | | | * 2010 (* 910) | * 2010 (* 910) | 1900 -860 | | | | * 2090 (* 950) | 1960 -890 | 1720 -780 | 10' 4" -3.16 |
| 9' 10" (3.0 m) | | | | | | | * 1870 (* 850) | * 1870 (* 850) | * 1870 (* 850) | * 2010 (* 910) | 1340 -610 | 1170 -530 | * 1760 (* 800) | 1320 -600 | 1150 -520 | 13' 3" -4.05 |
| 6' 7" (2.0 m) | | | | | | | * 2470 (* 1120) | 2070 -940 | 1810 -820 | * 2070 (* 940) | 1320 -600 | 1170 -530 | * 1700 (* 770) | 1100 -500 | 970 -440 | 14' 8" -4.47 |
| 3' 3" (1.0 m) | | | | | | | * 3310 (* 1500) | 1960 -890 | 1700 -770 | * 2360 (* 1070) | 1280 -580 | 1120 -510 | * 1760 (* 800) | 1040 -470 | 900 -410 | 15' 1" -4.59 |
| Ground Level | | | | * 3350 (* 1520) | * 3350 (* 1520) | 3000 -1360 | * 3750 (* 1700) | 1900 -860 | 1630 -740 | * 2540 (* 1150) | 1260 -570 | 1080 -490 | * 2010 (* 910) | 1080 -490 | 950 -430 | 14' 7" -4.45 |
| -3' 3" (-1.0 m) | * 4650 (* 2110) | * 4650 (* 2110) | * 4650 (* 2110) | * 6000 (* 2720) | 3680 -1670 | 3040 -1380 | * 3570 (* 1620) | 1870 -850 | 1630 -740 | | | | * 2270 (* 1030) | 1260 -570 | 1100 -500 | 13' 1" 3990 |
| -6' 7" (-2.0 m) | | | | * 4080 (* 1850) | 3790 -1720 | 3150 -1430 | * 2310 (* 1050) | 1960 -890 | 1700 -770 | | | | * 2180 (* 990) | 1920 -870 | 1650 -750 | 10' 3060 |

A Distance from center of rotation † Dozer blade in down position
B Height

NOTE: Lifting capacities are in compliance with SAE 1097 and ISO 10567. Machine in lifting mode with power boost turned on. Load point is the end of the arm. Rated loads shown do not exceed 75% of minimum tipping loads or 87% of hydraulic capacities. Rated loads marked with an asterisk (*) are limited by hydraulic capacities. The least stable position is over the side. The total mass of machine includes the mass of the boom, arm, counterweight, all operating fluids and 165 lb. (75 kg) operator.

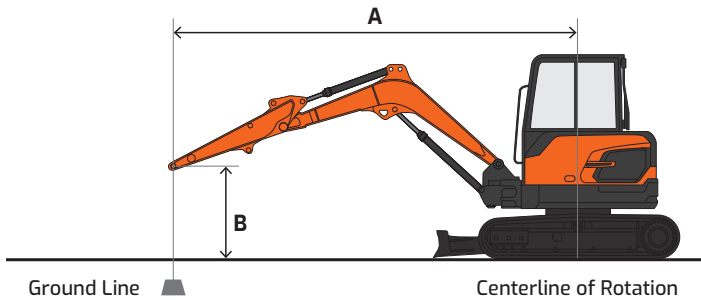

Standard & Optional Equipment

| Standard Base Package, US20

■ Standard ● Optional

Engine

| | |
|---|---|
| Emissions, T4 (EPA) | ■ |
| Direct fuel injected | ■ |
| Fuel filter with water separator | ■ |
| Coolant recovery tank | ■ |
| Dual element dry-type air filter | ■ |
| Electronic engine control | ■ |
| Auto preheat cold start assist | ■ |
| Auto idle | ■ |
| Overheat & low oil pressure engine protection | ■ |

Hydraulic

| | |
|--|---|
| Variable axial piston main pump | ■ |
| Pilot-operated control valves | ■ |
| Pilot gear pump (tandem) | ■ |
| Axial piston swing motor | ■ |
| Spring-applied hydraulic release brake | ■ |
| Axial piston travel motor (high/low, auto) | ■ |
| Auxiliary hydraulics, two-way | ■ |
| Adjustable auxiliary flow | ■ |

Electrical

| | |
|---------------------------------------|---|
| Alternator – 13.5 V, 75 amp | ■ |
| 12 V battery, 400 CCA @ 0° F (-18° C) | ■ |
| Light: cabin (1), boom (1) | ■ |
| Additional lighting | ● |
| Rotating beacon | ● |
| Hour meter | ■ |
| Engine restart prevention system | ■ |
| Laptop service port | ■ |
| Self-diagnostics system | ■ |

Cabin

| | |
|---------------------------------------|---|
| Steel, all-weather & sound suppressed | ■ |
| ROPS/TOPS | ■ |
| Front window with wiper/washer | ■ |
| Tinted safety glass | ■ |
| Skylight | ■ |
| Pull-up type front window | ■ |
| Lockable doors | ■ |
| Seat | ■ |
| - 2" (51 mm) seat belt | ■ |
| - Adjustable height & recline | ■ |
| Adjustable armrests | ■ |
| Air conditioner with heater | ■ |
| Mirrors | ■ |
| AM/FM stereo & Bluetooth® | ■ |
| Speakers (2) | ■ |
| Power socket, 12 V | ■ |
| Interior light | ■ |
| Storage for operator's manuals | ■ |

Controls

| | |
|--|---|
| Joystick controls | ■ |
| - Two hydraulic joysticks control boom, arm, bucket & slew functions | ■ |
| - Thumb buttons control auxiliary hydraulics & boom swing | ■ |
| Blade control lever | ■ |
| Pattern control change valve (SAE, ISO) | ■ |
| Engine speed control dial | ■ |
| Travel pedals with hand levers | ■ |
| Switches, console-mounted | ■ |
| - Starter switch (key) | ■ |
| - Heater/AC control panel | ■ |
| - Boom swing switch | ■ |
| - Rotating beacon (if equipped) | ■ |
| - 12 V power socket & USB charger | ■ |
| - Keypad buttons | ■ |
| - Overload warning | ■ |
| - Travel/swing alarm | ■ |
| - Light | ■ |
| - Work lights | ■ |
| - Wiper & washer | ■ |
| - Auto idle | ■ |
| Emergency stop switch | ■ |

Display Monitor & Warnings

| | |
|--|---|
| Buzzer | ■ |
| - Engine oil pressure | ■ |
| - Coolant temperature | ■ |
| Touch screen display monitor | ■ |
| - Digital clock | ■ |
| - Menu select button | ■ |
| - Back button | ■ |
| - Fuel gauge | ■ |
| - Engine coolant temperature | ■ |
| - Hydraulic oil temperature | ■ |
| - Mode | ■ |
| - Tachometer | ■ |
| - Operating mode/flow setting selector | ■ |
| Indicator lights | ■ |
| - Air filter restriction indicator | ■ |
| - Engine check warning light | ■ |
| - Hydraulic oil warning | ■ |
| - Fuel warning | ■ |
| - Auto idle indicator | ■ |
| - Auxiliary flow mode indicator | ■ |
| - Engine oil pressure light with audible alarm | ■ |
| - Pre-heat (cold start assist) indicator | ■ |
| - Two-speed travel indicator light | ■ |
| Travel alarm | ● |

Undercarriage

| | |
|------------------------------------|---|
| Track rollers, upper (1 each side) | ■ |
| Track rollers, lower (4 each side) | ■ |
| Rubber tracks – 300 mm | ■ |

Other

| | |
|--|---|
| Centralized lubrication | ■ |
| - Swing pinion | ■ |
| - Swing bearing | ■ |
| Dozer blade | ■ |
| Manuals | ■ |
| - Operation | ■ |
| - AEM Safety Manual | ■ |
| Vandalism protection | ■ |
| - Lockable panels | ■ |
| - Lockable fluid fill points | ■ |
| DEVELON Fleet Management 3-year subscription | ■ |

Certain specification(s) are based on engineering calculations and are not actual measurements. Specification(s) are provided for comparison purposes only and are subject to change without notice. Specification(s) for your individual DEVELON equipment will vary based on normal variations in design, manufacturing, operating conditions, and other factors. Pictures of DEVELON units may show other than standard equipment.

Powered by Innovation

DEVELON

A brand of HD Hyundai Infracore.

na.develon-ce.com/dx35z-7

DX35Z-7 Crawler Excavator Spec Sheet
Printed in the U.S.A.
23906_001_D060623

©2023 HD Hyundai Infracore. All rights reserved.