

# DEVELON

## Crawler Excavator

# DX170LC-5



### Engine

Make	Perkins
Model	1204F
Number of cylinders	4
Rated power, gross (hp per SAE J1349)	131.1 hp (97.9 kW) @ 2000 rpm
Rated power, net (hp per SAE J1349)	127.3 hp (94.9 kW) @ 2000 rpm
Max. torque, net (SAE J1995)	391 lbf.-ft. (530 Nm) @ 1400 rpm
Displacement	269 in. <sup>3</sup> (4.4 L)
Bore and stroke	4.1 in. x 5.0 in. (105 mm x 127 mm)
Starter	24 V, 6.0 hp (4.5 kW)
Battery	2 x 12 V, 100 AH
Alternator	24 V, 85 amp
Air cleaner	Double elements

### Hydraulics

Main pumps	2 x 40.15 gpm (2 x 152 L/min.)
Pilot pump (gear design)	8 gpm (30 L/min.)

### Working Pressure

Boom/arm/bucket (normal mode)	4694 psi (330 kg/cm <sup>2</sup> )
Boom/arm/bucket (power boost)	4978 psi (350 kg/cm <sup>2</sup> )
Travel	4694 psi (330 kg/cm <sup>2</sup> )
Swing	4694 psi (330 kg/cm <sup>2</sup> )
Pilot	568 psi (40 kg/cm <sup>2</sup> )

### Undercarriage

Upper rollers (each track)	2
Lower rollers (each track)	7
Number of shoes (links per side)	45

### Swing Mechanism

Swing speed	0 – 10.52 rpm
Swing torque	46653 lbf.-ft. (6450 kgf-m)

### Drive System

Travel speed (low – high)	1.93 – 3.11 mph (3.1 – 5.0 km/h)
Traction force, max. (drawbar pull)	45195 lbf.-ft. (6248 kgf-m)
Max. grade (limited by engine lub)	70% (35°)

### Environment

Sound level (2000/14/EC)	102 dB(A)
Cabin sound level (ISO 6396)	68 dB(A)

### Refill Capacities

Fuel tank	77.14 gal. (292 L)
DEF tank	5 gal. (19 L)
Cooling system (radiator capacity)	6.6 gal. (25 L)
Engine oil (with filler)	2.6 gal. (10 L)
Swing drive	1.3 gal. (5 L)
Final drive (each side)	0.08 gal. (3 L)
Hydraulic system	55.5 gal. (210 L)
Hydraulic tank	47.82 gal. (181 L)

### Hydraulic Cylinders

Boom (2) bore x rod diameter x stroke	4.5 in. x 3.1 in. x 41.9 in. (115 mm x 80 mm x 1064 mm)
Arm (1) bore x rod diameter x stroke	4.9 in. x 3.5 in. x 48.7 in. (125 mm x 90 mm x 1238 mm)
Bucket (STD) (1) bore x rod diameter x stroke	4.1 in. x 2.8 in. x 39.2 in. (105 mm x 70 mm x 995 mm)

The piston rods and cylinder bodies are made of high-strength steel. A shock-absorbing mechanism is fitted in all cylinders to ensure shock-free operation and extended piston life.

# Dimensions

**Standard Arm**  
1' 11" (600 mm) Shoe  
(US20)

Boom length		16' 8" (5100 mm)
Arm length		8' 2" (2500 mm)
Bucket type (SAE)		0.86 yd <sup>3</sup> (0.7 m <sup>3</sup> )
Track type		Fixed
Tail swing radius	A <sub>1</sub>	8' 3" (2530 mm)
Tail swing overhang (rear)	A <sub>2</sub>	7" (173 mm)
Tail swing overhang (side)	A <sub>3</sub>	3' 0" (910 mm)
Shipping height (boom)	B	9' 3" (2840 mm)
Shipping height (hose)	C	10' 0" (3060 mm)
Shipping length	D	27' 0" (8250 mm)
Shipping width	E	8' 6" (2590 mm)
Counterweight clearance	F	3' 1" (1009 mm)
Cabin height	G	9' 7" (2925 mm)
Upper structure width	H	8' 4" (2540 mm)
Cabin height above house	I	6' 10" (2085 mm)
Cabin width	J	3' 4" (1010 mm)
Tumbler distance	K	10' 9" (3275 mm)
Overall track length	L	13' 4" (4065 mm)
Undercarriage width	M	8' 6" (2590 mm)
Track gauge	N	6' 6" (1990 mm)
Track shoe width	O	1' 11" (600 mm)
Track height	P	3' 0" (915 mm)
Car body clearance	Q	1' 5" (434 mm)

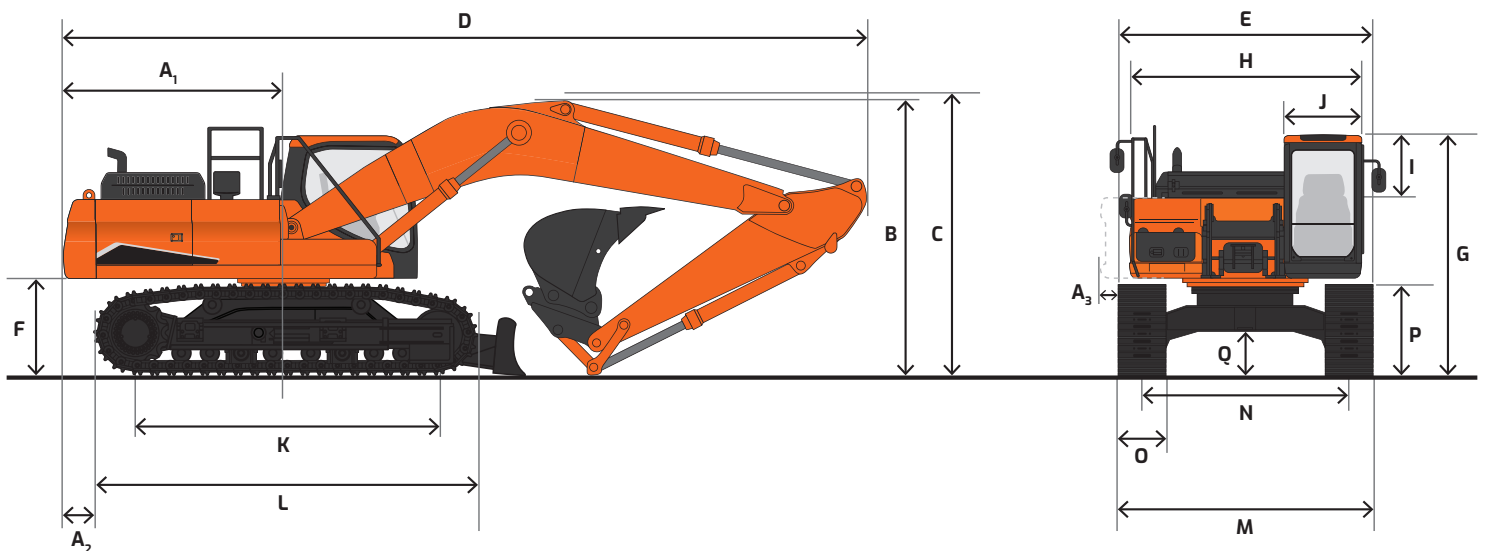

# Working Range

**Standard Arm**  
1' 11" (600 mm) Shoe  
(US20)

Boom length	16' 8" (5100 mm)	
Arm length	8' 2" (2500 mm)	
Bucket type (SAE, PCSA)	0.86 yd <sup>3</sup> (0.7 m <sup>3</sup> )	
Track type	Fixed	
Max. digging reach	A	29' 5" (8965 mm)
Max. digging reach (ground)	B	28' 10" (8790 mm)
Max. digging depth	C	20' 0" (6085 mm)
Max. loading height	D	21' 4" (6505 mm)
Min. loading height	E	8' 0" (2445 mm)
Max. digging height	F	29' 9" (9070 mm)
Max. bucket pin height	G	25' 9" (7850 mm)
Max. vertical wall depth	H	16' 7" (5055 mm)
Max. radius vertical	I	18' 9" (5725 mm)
Max. depth to 8' line	J	19' 3" (5860 mm)
Min. radius to 8' line	K	6' 10" (2085 mm)
Min. digging reach	L	1' 11" (575 mm)
Min. swing radius	M	10' 5" (3165 mm)
Bucket angle (DEG)	d	178°
Digging force, bucket (PCSA)	ISO	25794 lbf. (11700 kgf)
Digging force, arm		18078 lbf. (8.2 kgf)
Operating weight	38376 lb. (17407 kg)	
Ground pressure	5.55 psi (39 kg/cm <sup>2</sup> )	

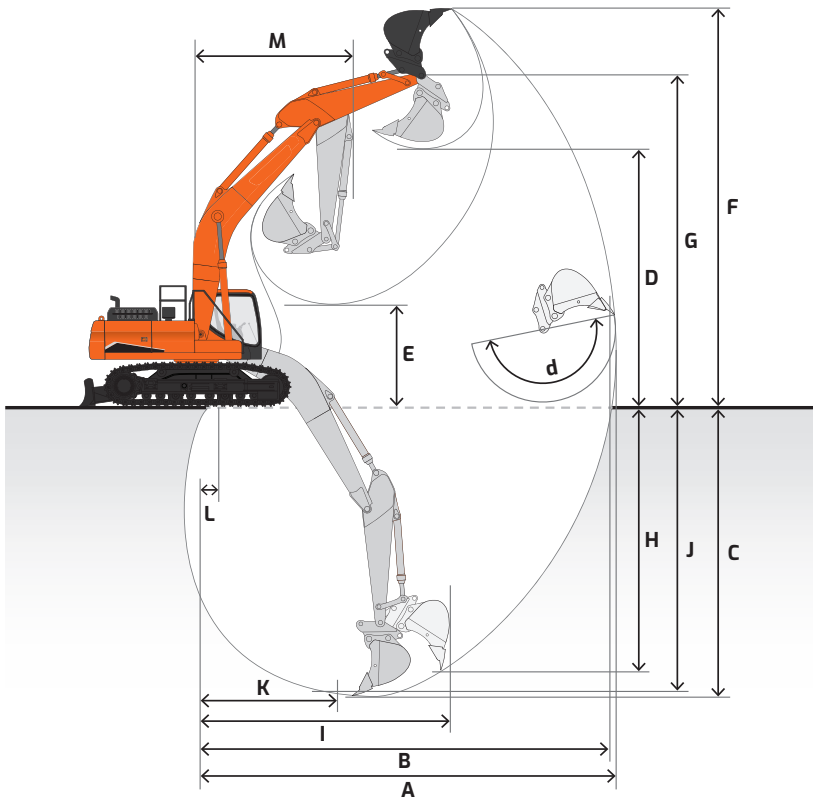

# Bucket

## Standard Arm (US20)

<b>Boom</b>	16' 8" (5100 mm)	
<b>Arm</b>	8' 2" (2500 mm)	
<b>Shoe size</b>	1' 11" (600 mm)	
<b>Track type</b>	Fixed	
<b>Mount</b>	Pin-on	Quick-coupler
<b>Counterweight</b>	5754 lb. (2610 kg)	

Bucket Type	Model	Capacity* yd <sup>3</sup> (m <sup>3</sup> )	Width in. (mm)	Weight lb. (kg)		
Heavy-duty	HD17-024	0.50 (0.38)	24 (610)	1095 (497)	A	A
	HD17-030	0.68 (0.52)	30 (762)	1190 (540)	A	A
	HD17-036	0.86 (0.66)	36 (914)	1338 (607)	A	A
	HD17-042	1.04 (0.80)	42 (1067)	1448 (657)	A	B
	HD17-048	1.22 (0.93)	48 (1219)	1584 (719)	B	C
Severe-duty	SD17-024	0.50 (0.38)	24 (610)	1151 (522)	A	A
	SD17-030	0.68 (0.52)	30 (762)	1264 (573)	A	A
	SD17-036	0.86 (0.66)	36 (914)	1417 (643)	A	A
	SD17-042	1.04 (0.80)	42 (1067)	1531 (694)	A	B
	SD17-048	1.22 (0.93)	48 (1219)	1681 (762)	B	C
Ditching	DC17000-060	1.22 (0.93)	60 (1524)	1395 (633)	*	*
Heavy-Duty Ditching	DCHD17000-060	1.58 (1.21)	60 (1524)	1887 (856)	*	*

\*Capacity based on ISO 7451 and heaped with a 1:1 angle of repose

· Equipped with bolt-on wear shrouds

· Equipped with bolt-on teeth

· Equipped with bolt-on cutting edge

· These recommendations are given as a guide only and based on typical operating conditions.

### Maximum Suitable Material Density

A 3370 lb./yd<sup>3</sup> (2000 kg/m<sup>3</sup>)

B 2700 lb./yd<sup>3</sup> (1600 kg/m<sup>3</sup>)

C 1850 lb./yd<sup>3</sup> (1100 kg/m<sup>3</sup>)

X Not Approved

\* Based on designed use, not material capacity.













Please consult with your DEVELON dealer to properly match buckets and attachments for the application.

# Lifting Capacity

 Rating over front     Rating over side or 360°

## DX170LC-5 US20

Boom: 16' 9" (5100 mm) | Arm: 8' 2" (2500 mm) | Counterweight: 5754 lb. (2610 kg) | 24" (600 mm) Shoes | No Dozer | Bucket: None | Unit: lb. (kg)

B (ft. or m)	5' (1.5 m)		10' (3.0 m)		15' (4.5 m)		20' (6.0 m)		25' (7.5 m)		Max. Reach		
													
25' (7.5 m)											* 5900 (* 2670)	* 5900 (* 2670)	16.23' (4.95 m)
20' (6.0 m)							* 7780 (* 3530)	7030 (3190)			* 5080 (* 2300)	* 5080 (* 2300)	20.84' (6.35 m)
15' (4.5 m)					* 9850 (* 4470)	* 9850 (* 4470)	* 9090 (* 4120)	6920 (3140)			* 4820 (* 2190)	* 4820 (* 2190)	23.52' (7.17 m)
10' (3.0 m)					* 12810 (* 5810)	10090 (4570)	* 10310 (* 4680)	6620 (3000)	* 6200 (* 2810)	4690 (2130)	* 4850 (* 2200)	4590 (2080)	24.92' (7.60 m)
5' (1.5 m)					* 15800 (* 7170)	9380 (4250)	10770 (4880)	6310 (2860)	7710 (3500)	4570 (2070)	* 5130 (* 2330)	4390 (1990)	25.28' (7.70 m)
Ground Level					16390 (7430)	8990 (4080)	10510 (4770)	6080 (2760)	* 5850 (* 2660)	4500 (2040)	* 5720 (* 2600)	4490 (2040)	24.63' (7.51 m)
-5' (-1.5 m)	* 13320 (* 6040)	* 13320 (* 6040)	* 21330 (* 9670)	16480 (7480)	16280 (7380)	8900 (4040)	10430 (4730)	6010 (2730)			* 6900 (* 3130)	4970 (2250)	22.86' (6.97 m)
-10' (-3.0 m)	* 22540 (* 10220)	* 22540 (* 10220)	* 22750 (* 10320)	16820 (7630)	* 15710 (* 7130)	9050 (4100)	* 10020 (* 4550)	6180 (2800)			* 9550 (* 4330)	6170 (2800)	19.73' (6.01 m)
-15' (-4.5 m)			* 15920 (* 7220)	* 15920 (* 7220)							* 10550 (* 4790)	10140 (4600)	14.20' (4.33 m)

A Distance from center of rotation  
B Height

NOTE: Lifting capacities are in compliance with SAE 1097 and ISO 10567. Machine in lifting mode with power boost turned on. Load point is the end of the arm. Rated loads shown do not exceed 75% of minimum tipping loads or 87% of hydraulic capacities. Rated loads marked with an asterisk (\*) are limited by hydraulic capacities. The least stable position is over the side. The total mass of machine includes the mass of the boom, arm, counterweight, all operating fluids and 165 lb. (75 kg) operator.

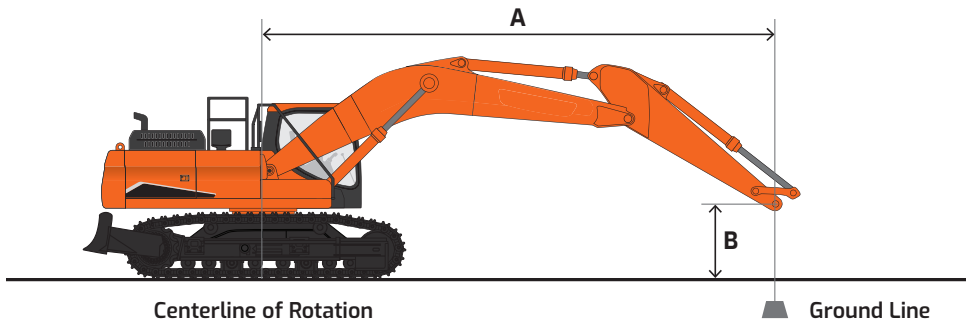

# Standard & Optional Equipment

■ Standard    ● Optional

## Engine

Emissions	T4f
High-pressure common-rail (HPCR)	■
Turbo, waste gate (WGT)	■
Cooled exhaust gas recirculation (CEGR)	■
Diesel oxidation catalyst (DOC)	■
Selective catalyst reduction (SCR)	■
Diesel exhaust fluid (DEF)	■
Fuel filter with water separator	■
Coolant expansion tank	■
Dual element dry-type air filter with evacuator	■
Precleaner	■
Electronic engine control (ECU)	■
Auto idle	■
Auto shutdown (time-adjustable)	■
Overheat & low oil pressure engine protection	■
Block heater (110 V)	●
Fuel filler pump	●

## Hydraulic

Electronic Power Optimizing System (EPOS)	■
Variable axial piston main pump (tandem)	■
Cross-sensing pump control	■
Pilot-operated control valves	■
Gear pilot pump	■
Smart Power Control (SPC)	■
Variable-speed hydraulic cooling fan	■
Axial piston swing motor	■
Spring-applied hydraulic release brake, swing motor	■
Axial piston travel motor (high/low, auto)	■
Auxiliary hydraulics, one-way	■
Auxiliary hydraulics, two-way	●
One-way/two-way piping	■
Auxiliary hydraulics, tilt/rotate piping	●
Adjustable auxiliary flow & pressure, 10 presets	■
Intelligent floating boom	●
Boom & arm lock valves	●

## Controls

Joystick controls	■
Pattern control change valve (SAE, ISO)	■
Joystick attachment control	■
Switches/buttons	■
- Right (one-way, two-way, power boost)	■
- Left (tilt/rotate, horn, one-touch decel)	■
Foot pedal attachment control	■
Control stands	■
- Height adjustable	■
- Sliding (fore/aft)	■
Engine speed control dial	■
Travel pedals with hand levers	■
Straight travel pedal	●
Switches, console-mounted	■
- Starter button switch	■
- Travel speed selector	■
- Work light	■
- Auxiliary mode switch	■
Emergency stop switch	■
Power modes (P+, P, S, E)	■
Work modes (digging, lifting, breaker, shear)	■
Smart Power Control (SPC)	■
Jog dial display control	■
Wiper control panel	■
Audio control panel	■

## Cabin

Steel, all-weather & sound-suppressed	■
ROPS (ISO 12117-2:2008)	■
Viscous mount with spring reinforcement	■
Front window with wiper/washer	■
Tinted safety glass	■
Skylight top hatch with sun screen	■
Front window with sun screen	■
Pull-up type top front window	■
Removable lower front window with storage behind seat	■
Adjustable sliding side door window	■
Defrost, front window	■
Lockable doors	■
Seat	■
- Heated	■
- Air suspension	■
- 2" (51 mm) seat belt	■
- Adjustable height & recline	■
- Adjustable fore/aft	■
- Adjustable armrests	■
3" (76 mm) seat belt	●
Control stands	■
- Height adjustable	■
- Mounted to seat base	■
Storage for operator's manuals	■
Mirrors	■
Fully automatic HVAC with ambient temperature sensor	■
7" multi-function LCD interactive display monitor	■
Cigarette lighter	■
AM/FM stereo with MP3 port	■
Speakers (2)	■
Antenna, roof-mounted	■
Emergency breakout tool	■
Hot/cold beverage compartment	■
Power socket, 12 V	■
Cup holder	■
Interior light	■
Coat hanger	■
Rain shield	●
Fog guard	●
Front window guard	●

## Electrical

System voltage – 24 V	■
Alternator – 24 V, 85 amp	■
2 x 12 V batteries, 100 AH reserve capacity, 900 CCA	■
Blade-type fuse panel	■
Main circuit breaker	■
Light, work (halogen): machine (2), boom (2)	■
Light, work (halogen): 6 cabin, front (4), rear (2)	●
Light, work (halogen): 2 cabin	●
Rotating beacon	●
Hour meter	■
Engine restart prevention system	■
Side view & rearview camera	■
Laptop service port	■
Self-diagnostics system	■
DEVELON Fleet Management	■

## Display Monitor & Warnings

Gauges	■
- Fuel level	■
- DEF level	■
- Engine coolant temperature	■
- Hydraulic oil temperature	■
- Engine rpm	■
- Battery voltage	■
- Hydraulic pump pressure	■
- ECO	■
- Digital clock	■
- Trip meter	■
- Hour meter	■
- Fuel consumption	■
Warning & indicator lights	■
- Seat belt	■
- Error code	■
- SCR warning	■
- Check engine	■
- Engine oil pressure	■
- Engine pre-heat engaged	■
- Radiator coolant level & temperature	■
- Air filter	■
- Fuel level	■
- DEF level – low	■
- Water in fuel	■
- Battery charge	■
- Work lights on	■
- Hydraulic oil temperature	■
- Hydraulic charge pressure	■
- Hydraulic pilot filter	■
- Hydraulic return filter	■
Swing alarm	●
Travel alarm	■
Buzzer	■
- Engine oil pressure	■
- Coolant temperature	■

## Undercarriage

Track guards & chains with adjusters	■
Track rollers, upper	2
Track rollers, lower	7
In-shoe motor protection	■
Shoes, triple grouser – 500 mm, rubber shoe (road liner)	■
Shoes, triple grouser – 500 mm	●
Shoes, triple grouser – 600 mm	■
Shoes, triple grouser – 900 mm	■

## Other

Centralized lubrication	■
- Boom	■
- Swing	■
Handrails & service platforms	■
Skid-resistant steps & service platforms	■
Manuals	■
- Operation & Maintenance	■
- AEM Safety Manual	■
DEVELON Fleet Management 3-year subscription	■
Vandalism protection	■
- Lockable panels	■
- Lockable fluid fill points	■
- Anti-theft protection (password)	■
- Vandalism window cover mount	■
Air compressor	●

Certain specification(s) are based on engineering calculations and are not actual measurements. Specification(s) are provided for comparison purposes only and are subject to change without notice. Specification(s) for your individual DEVELON equipment will vary based on normal variations in design, manufacturing, operating conditions, and other factors. Pictures of DEVELON units may show other than standard equipment.

# Powered by Innovation

# DEVELON

A brand of HD Hyundai Infracore.

[na.develon-ce.com/dx170lc-5](http://na.develon-ce.com/dx170lc-5)

DX170LC-5 Crawler Excavator Spec Sheet  
Printed in the U.S.A.  
23906\_001\_D060523

©2023 HD Hyundai Infracore. All rights reserved.